

U851A

133 dB (phantom) or 123 dB (battery) with a dynamic range of 111 dB (phantom) or 101 dB (battery). Nominal open-circuit output voltage shall be 10.0 mV (phantom) or 8.9 mV (battery) at 1 V, 1 Pascal. Output shall be low impedance balanced (200 ohms – phantom, 270 ohms – battery). It shall offer outstanding rejection of radio frequency interference (RFI).

The microphone shall have a 7.6 m (25') permanently attached miniature cable terminating in a special TA3F-type output connector designed to optimize RFI immunity. The output connector shall connect to a TB3M-type jack on the included power module. The power module shall house the battery, and shall contain a switch that permits choice of off, on/flat response, or on/low-roll-off (80 Hz). The output of the power module shall be a 3-pin XLRM-type connector.

The microphone shall be equipped with an integral rotating output connector that allows the cable to exit from either the rear or the bottom of the microphone without the need to disassemble the microphone or use tools to change the cable exit location.

The microphone shall have a maximum width of 84.0 mm (3.31"), a maximum length of 108.0 mm (4.25") and a maximum height of 23.0 mm (0.91"). Weight shall be 244 grams (8.6 oz). The microphone shall be housed in a die-cast case with a perforated steel grille. Finish shall be low-reflectance black. The microphone shall include a power module, a battery and a soft protective pouch.

The Audio-Technica U851A is specified.

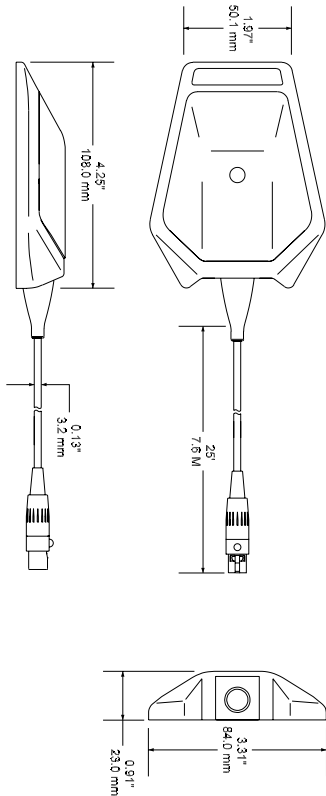

Specifications

| | |
|--|--|
| Element | Fixed-charge back plate, permanently polarized condenser |
| Polar pattern | Half-cardioid (cardioid in hemisphere above mounting surface) |
| Frequency response | 30-20,000 Hz |
| Low frequency roll-off | 80 Hz, 18 dB/octave |
| Open circuit sensitivity | Phantom: -40 dB (10.0 mV) re 1V at 1 Pa Battery: -41 dB (8.9 mV) re 1V at 1 Pa |
| Impedance | Phantom: 200 ohms Battery: 270 ohms |
| Maximum input sound level | Phantom: 133 dB SPL, 1 kHz at 1% T.H.D. Battery: 123 dB SPL, 1 kHz at 1% T.H.D. |
| Dynamic range (typical) | Phantom: 111 dB, 1 kHz at Max SPL Battery: 101 dB, 1 kHz at Max SPL |
| Signal-to-noise ratio¹ | 72 dB, 1 kHz at 1 Pa |
| Phantom power requirements | 11-52V DC, 2 mA typical |
| Battery type | 1.5V AA/UM3 |
| Battery current / life | 0.4 mA / 1200 hours typical (alkaline) |
| Switch | Off, on-flat, on-roll-off |
| Weight | Microphone: 244 g (8.6 oz) Power module: 139 g (4.9 oz) |
| Dimensions | Microphone: 108.0 mm (4.25") maximum length, 84.0 mm (3.31") maximum width, 23.0 mm (0.91") maximum height, Power module: 84.0 mm (3.31") H x 63.0 mm (2.48") W x 22.0 mm (0.87") D |
| Output connector | Power module: Integral 3-pin XLRM-type |
| Cable | 7.6 m (25.0') long (permanently attached to microphone), 3.2 mm (0.13") diameter, 2-conductor, shielded cable with TA3F-type connector |
| Optional interchangeable elements | UE-O omnidirectional (360°) UE-H hypercardioid (100°) |
| Accessories furnished | AT8531 power module; battery; soft protective pouch |

In the interest of standards development, A.T.U.S. offers full details on its test methods to other industry professionals on request.

1 Pascal = 10 dynes/cm² = 10 microbars = 94 dB SPL

¹ Typical, A-weighted, using Audio Precision System One.

Specifications are subject to change without notice.



frequency response: 30–20,000 Hz

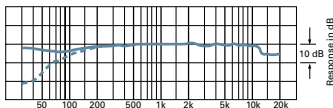

LEGEND — 12° or more on axis
--- Roll-off

polar pattern

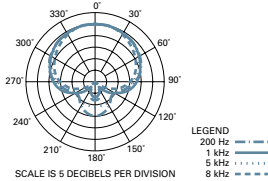

Audio-Technica U.S., Inc., 1221 Commerce Drive, Stow, Ohio 44224
Audio-Technica Limited, Old Lane, Leeds LS11 8AG England
©2010 Audio-Technica U.S., Inc. audio-technica.com