

U100 Series

Camera-mount UHF Wireless Microphone Systems

ATW-U101 Body-pack Transmitter System

ATW-U101x Body-pack Transmitter System

ATW-U102 Plug-on Transmitter System

ATW-U102x Plug-on Transmitter System

Installation and Operation

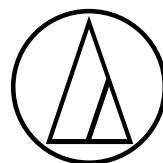

audio-technica®

U100 Series Compatible with 7000 Series Wireless

For greater convenience and flexibility, receivers and transmitters in the Audio-Technica U100 Series and 7000 Series are available individually and may be used interchangeably. All are 100-channel, PLL-synthesized UHF units operating in one of two UHF frequency ranges: "x" units in 656-668 MHz, and non-"x" units in 728-740 MHz. Model "x" transmitters must be used only with "x" receivers; the same holds true for non-"x" transmitters and receivers.

Series	Receiver	Description
U100	ATW-R100(x)	Miniaturized, battery-powered receiver
7000	ATW-R73(x)	Half-rack-mount, AC-powered receiver
Series	Transmitter	Description
U100	ATW-T101(x)	Body-pack transmitter, metal case, TB5M input connector
U100	ATW-T102(x)	Plug-on transmitter for separate microphone
7000	ATW-T73(x)	Integrated handheld condenser microphone/transmitter
7000	ATW-T75(x)	Body-pack transmitter, plastic case, HRS input connector (Requires A-T mics with model numbers ending in "cW.")
7000	ATW-T76(x)	Integrated handheld dynamic microphone/transmitter

U100 Series Camera-mount UHF Wireless Microphone Systems

Installation and Operation

This device complies with part 15 of the FCC Rules. Operation is subject to the condition that this device does not cause harmful interference.

This device complies with INDUSTRY CANADA R.S.S. 210, en conformité avec IC: RSS-210/CNR210. Operation is subject to the following conditions: 1) This device may not cause harmful interference and 2) this device must accept any interference received, including interference which may cause undesired operation.

Notice to individuals *with implanted cardiac pacemakers or AICD devices:*

Any source of RF (radio frequency) energy *may* interfere with normal functioning of the implanted device. All wireless microphones have low-power transmitters (less than 0.05 watts output) which are unlikely to cause difficulty, especially if they are at least a few inches away. However, since a "body-pack" mic transmitter typically is placed against the body, we suggest attaching it at the belt, rather than in a shirt pocket where it may be immediately adjacent to the medical device. Note also that *any medical-device disruption will cease when the RF transmitting source is turned off*. Please contact your physician or medical-device provider if you have any questions, or experience any problems with the use of this or any other RF equipment.

CAUTION! The circuits inside the receiver and transmitter have been precisely adjusted for optimum performance and compliance with federal regulations. Do not attempt to open the receiver or transmitter. To do so will void the warranty, and may cause improper operation.



Warning: To prevent fire or shock hazard, do not expose this appliance to rain or moisture.

Attention: Pour prévenir feu ou choc électrique, ne pas exposer l'appareil à la pluie ou à l'humidité.

Introduction

Thank you for choosing an Audio-Technica professional wireless system. You have joined thousands of other satisfied customers who have chosen our products because of their quality, performance and reliability. This Audio-Technica wireless system is the successful result of years of design and manufacturing experience.

The U100 systems are designed primarily for use in audio-for-video applications, with the receiver mounted on a camera and connected to the camera's audio input. U100 systems provide a choice of 100 PLL-synthesized UHF frequencies in one of two UHF frequency ranges: "x" units in 656-668 MHz, and non-"x" units in 728-740 MHz. Each system includes a receiver and either a body-pack or plug-on transmitter:

System	Receiver	Transmitter
ATW-U101	ATW-R100	ATW-T101 Body-pack
ATW-U101x	ATW-R100x	ATW-T101x Body-pack
ATW-U102	ATW-R100	ATW-T102 Plug-on
ATW-U102x	ATW-R100x	ATW-T102x Plug-on

The ATW-R100(x) receiver features true diversity reception. Two antennas feed two completely independent RF sections on the same frequency; automatic logic circuitry continuously compares and selects the superior received signal, providing better sound quality and reducing the possibility of dropouts. Front-end helical filter design improves rejection of interference. The receiver also offers balanced audio output with level control, a headphone jack with volume control, removable antennas, a hinged battery door, and LED indicators. It operates on two internal 9V batteries or external 12V DC.

Each transmitter is powered by one internal 9V battery and has an Off/Standby/On switch, input level control, battery condition indicator and channel selector switches. The ATW-T101(x) body-pack transmitter has an industry-standard TB5M input connector with both low- and high-impedance inputs plus a bias connection. The ATW-T102(x) has a 3-pin XLR-type input connector with a locking collar.

Note: Since "x" and non-"x" units operate in different frequency ranges, they are not compatible. Model "x" transmitters must be used only with "x" receivers; the same holds true for non-"x" transmitters and receivers.

Please note that in multiple system applications there must be a transmitter-receiver combination set to a **separate** frequency for each input desired (only one transmitter for each receiver). Because the operating frequencies of U100 Systems are in UHF TV frequencies, only certain wireless frequencies may be useable in a particular geographic area. Also, only certain of the available operating frequencies may be used together. Suggestions for multiple-system frequency grouping will be found on pages 9 and 10.

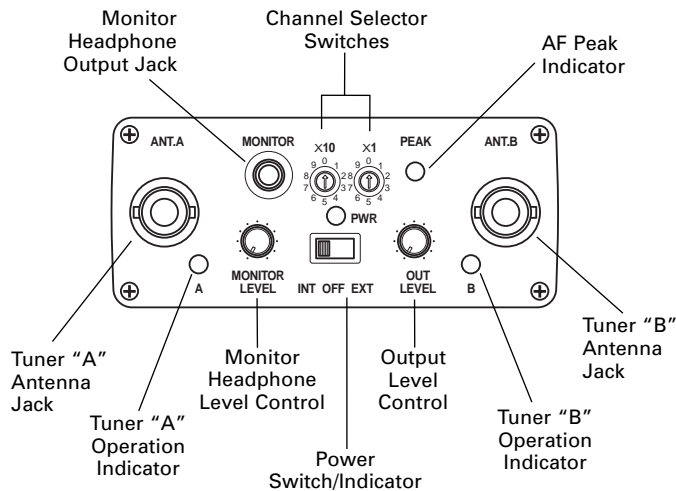

Fig. A

Location

The ATW-R100(x) receiver is designed primarily to be mounted to professional video cameras using the included hook & loop fasteners (mounting methods and positions will vary with the camera being used). However, the receiver will provide outstanding professional performance in other wireless applications as well.

For best operation the receiver should be at least three feet above the ground and at least three feet away from a wall or metal surface to minimize reflections. The transmitter should be at least three feet from the receiver.

Keep antennas away from noise sources such as computers, motors, automobiles and neon lights; also keep antennas away from large metal objects.

Output Connections

There is one balanced audio output (31.6 mV) on the back panel of the receiver. Use shielded audio cable to connect this XLRM-type 3-pin jack to the mic audio input of the camera or mixer. (The optional AT8341 cable, 19" long, terminates in a right-angle 3.5 mm stereo mini-plug.)

A headphone jack and level control permit monitoring of the audio signal. Either mono or stereo headphones with a 3.5 mm plug may be used; the audio is supplied to both sides of a stereo unit.

Antennas

Attach the antennas to the antenna input jacks. Make certain that during operation there is a clear open-air path between the receiver antennas and the transmitter.

Power

The ATW-R100(x) receiver operates on either external DC or internal battery power by setting the Power switch to "EXT" or "INT" respectively (Fig. A). In the center position all power is off.

External Power

The back panel is equipped with a jack for an external 12-18V DC source, 200 mA nominal current. The jack takes a standard 2.5 mm I.D. coaxial DC power plug, center **positive**.

Battery Selection and Installation

Always use two fresh alkaline 9V batteries. Replace the batteries in pairs. Turn the Power switch "Off" before inserting the batteries.

Open the hinged battery door on the side of the receiver. Insert two batteries, observing correct polarity as marked on the inside of the door. Close and latch the door.

Note that the battery door will not close fully if the batteries are installed incorrectly. **Do not force the door closed.**

The U100 Series receiver and transmitters accept most popular brands of 9-volt alkaline batteries. But there is considerable variation in battery sizes; some alkaline and extended-life batteries may not fit correctly, which can cause units to operate improperly or not at all.

Plug-on Transmitter Setup

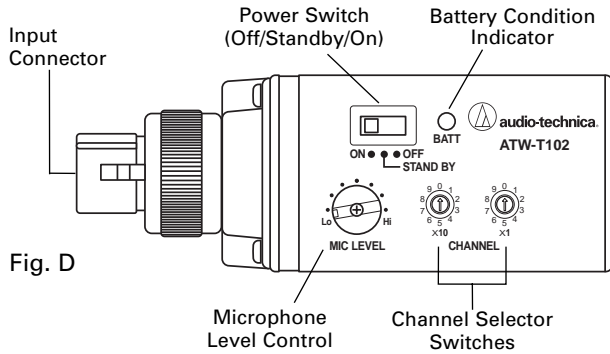

Fig. D

Battery Selection and Installation

Always use a fresh alkaline 9V battery. Turn the Power switch "Off" before inserting a battery.

Open the hinged battery door. Insert the battery, observing correct polarity as marked inside the battery compartment. Close the battery door. **Do not force the door closed.**

Battery Condition Indicator

After the battery is installed, turn the power on. The battery condition indicator LED (Fig. D) should flash momentarily. If it does not, the battery is installed incorrectly or it is dead.

If the indicator LED stays on (does not flash), the battery voltage is low and the battery should be replaced. If this happens during use, replace the battery immediately to ensure continued operation.

ATW-T102(x) Microphone Input

The ATW-T102(x) plug-on transmitter has a 3-pin XLR-type input connector with a locking collar. Use a dynamic microphone, or a condenser mic with an internal battery. To attach the microphone, rotate the threaded locking collar **fully** clockwise ("down") until it reaches the transmitter housing (Fig. E1). Then rotate the collar back "up" one or two turns to expose the microphone latch.

Press the microphone and transmitter together (Fig. E2), making certain that the latch "clicks" into the base of the mic. Pull on the mic to make certain it is latched on the connector.

Continue to rotate the threaded collar "up" until it is **firmly** against the end of the mic (Fig. E3). Make certain the mic is securely attached before use.

To detach the microphone, reverse the steps above. **Always** loosen the threaded collar **fully** before attempting to disconnect the mic.

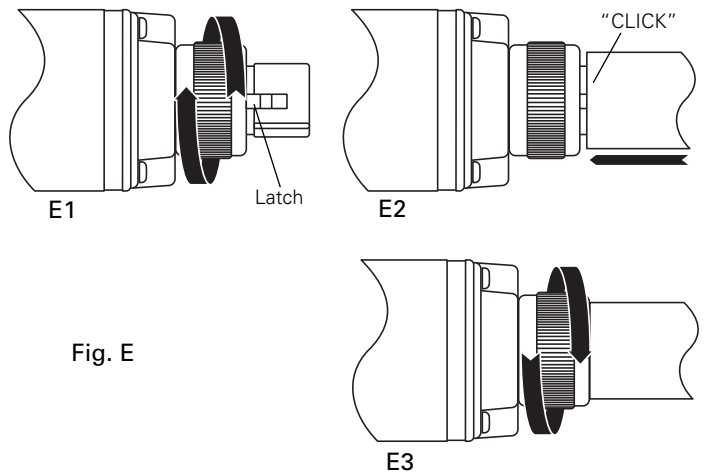

Fig. E

The ATW-T102(x) provides a bias voltage of +5V on Pins 2 and 3 which will power some "battery/phantom" mics designed to work at this low voltage. However, the ATW-T102(x) will not power a "phantom powered" mic which requires the more-typical 12 to 48 volts. Use of the bias voltage will reduce battery life slightly. Presence of the bias voltage will not affect dynamic microphones.

Pin 1	Case Ground
Pin 2	Audio "+" and 5V DC bias
Pin 3	Audio "-" and 5V DC bias

Transmitting Antenna

The ATW-T102(x) plug-on transmitter's antenna is housed in a non-metallic section between the metal transmitter case and the mic connector. For best operation, hold the body of the microphone itself and do not cover or obstruct the antenna area.

Setting Channels

Use the provided screwdriver to set the channel selector switches on the receiver and transmitter to the same frequency (Fig. A/C/D).

As an example using a non-"x" unit, setting the X10 selector on "5" and the X1 selector on "2" designates channel 52, operating at 734.625 MHz as shown on the chart on page 9. (With an "x" unit, channel 52 is 662.625 MHz, as shown on page 10.)

Be certain the units are turned off when making frequency changes.

Receiver On . . .

Turn down the output level of the receiver (OUT LEVEL) and the input level control of the camera or mixer.

Turn the receiver on, choosing either "INT" (internal battery) or "EXT" (external DC source) as appropriate. The power indicator LED (PWR) will light up strongly with fresh batteries. (If the LED becomes dim or extinguished, the batteries are weak and should be replaced immediately for reliable operation.)

If the tuner operation indicator LEDs (A and B) flicker, there may be RF interference. If this occurs, select another frequency. (Always turn the receiver off when making frequency changes.)

Transmitter On . . .

Before turning on the transmitter, be certain the transmitter channel selector switches are set to the same numbers as those on the receiver.

Turn the transmitter on.

The transmitter has a three-position power switch. When the switch is set to "Standby," ("ST.BY"/"STAND BY") the transmitter produces RF with no audio signal. When the switch is "On," the transmitter produces both RF and audio. With the switch "Off," there is minimum noise output from the receiver due to a special A-T muting system.

Setting Mic Levels

CAUTION! Adjust the Mic Level control *carefully*. Unlike the Channel Selector switches, it will *not* rotate continuously!

The microphone input accommodates a wide range of mics with typical sensitivity ratings of 1.5 mV (-56 dBV) to 15 mV (-36 dBV) at 1 Pascal/94 dB SPL, while providing excellent signal-to-noise ratios and maximum-acoustic-input levels.

1. Plug in the mic and power up the system.
2. Set the Mic Level control to the full clockwise (Hi) position. Speak/sing into the microphone at typically-loud levels while watching the Peak indicator on the receiver. If the Peak indicator lights, turn the Mic Level control down (counter-clockwise) only to the point where the indicator light no longer illuminates. (When the AF Peak indicator lights, the transmitter audio level is driving the receiver into distortion. For best audio, the Mic Level should be set as high as possible, but not so high as to light the Peak indicator.)
3. Now, while speaking/singing into the microphone at typically-loud levels, adjust the output level of the receiver so the highest sound pressure level going into the microphone causes no input overload in the camera/mixer, and yet permits the camera/mixer level controls to operate in their "normal" range (not set too high or too low). This provides the optimum signal-to-noise for the entire system.

Setting Line Level – ATW-T101(x)

When using a Hi-Z line-level source with the ATW-T101(x) transmitter, set the input level using the same method given above. The Mic Level (MIC LVL) control adjusts audio gain for both mic and line inputs.

RF Interference

Please note that wireless frequencies are shared with other radio services. According to Federal Communications Commission regulations, "Wireless microphone operations are unprotected from interference from other licensed operations in the band. If any interference is received by any Government or non-Government operation, the wireless microphone must cease operation . . ."

If you need assistance with operation or frequency selection, please contact your dealer or the Audio-Technica professional division.

Extensive wireless information also is available on the Audio-Technica Web site at www.audio-technica.com.

Specifications†

Overall System

UHF Operating Frequency	
"x" systems	656.125-668.500 MHz
non-"x" systems	728.125-740.500 MHz
Number of Channels	100 total
Frequency Stability	±0.005%, Phase Lock Loop frequency control
Modulation Mode	FM
Normal Deviation	±10 kHz
Operating Range	300' typical (ATW-U102: 200' typical)
Operating Temperature Range	41° F (5° C) to 113° F (45° C)
Frequency Response	100 Hz to 15 kHz

ATW-R100(x) Receiver

Receiving System	Dual independent receivers, automatic switching diversity
Image Rejection	35 dB nominal
Signal-to-Noise Ratio	107 dB at 30 kHz deviation (IEC-weighted), maximum modulation 75 kHz
Total Harmonic Distortion	<1% (10 kHz deviation at 1 kHz)
Sensitivity	26 dBµV, (S/N 60 dB at 5 kHz deviation, IEC-weighted)
Intermediate Frequency	45 MHz, 10.7 MHz
Audio Output (balanced)	31.6 mV (at 1 kHz, ±5 kHz deviation, 10k ohm load)
Output Connector	3-pin XLRM-type
Monitor Headphone Output (typical)	75 mW max. at 1 kHz, 1% T.H.D., into 32 ohm (each channel) stereo headphones
Monitor Headphone Jack	3.5 mm TRS, signal on both Tip and Ring
External Power Requirements	12V DC nominal, 200 mA
Batteries	Two 9V (NEDA type 1604) alkaline, not included
Current Consumption	130 mA typical
Battery Life	Approximately 5-7 hours (depending on battery type and use pattern)
Dimensions	3.35" (85.0 mm) W x 4.53" (115.0 mm) H x 1.42" (36.0 mm) D
Net Weight (without batteries)	12.0 oz (340 grams)
Accessories Included	Two flexible UHF antennas; control screwdriver; mounting pouch; hook & loop fasteners

ATW-T101(x) Body-pack Transmitter

RF Power Output	10 mW typical
Spurious Emissions	Under federal regulations
Input Connector	TB5M
Line Input Impedance/Level	100k ohms/3.16V max. input at 1 kHz, 1% T.H.D.
Battery	9V (NEDA type 1604) alkaline, not included
Current Consumption	50 mA typical
Battery Life	Approximately 7-9 hours (depending on battery type and use pattern)
Dimensions	2.52" (64.0 mm) W x 3.78" (96.0 mm) H x 0.91" (23.0 mm) D
Net Weight (without battery)	5.0 oz (143 grams)
Accessory Included	Control screwdriver

ATW-T102(x) Plug-on Transmitter

RF Power Output	10 mW typical
Spurious Emissions	Under federal regulations
Input Connector	3-pin XLRF-type
Battery	9V (NEDA type 1604) alkaline, not included
Current Consumption	60 mA typical
Battery Life	Approximately 7-9 hours (depending on battery type and use pattern)
Dimensions	1.58" (40.0 mm) W x 4.32" (109.8 mm) H x 1.58" (40.0 mm) D
Net Weight (without battery)	6.2 oz (177 grams)

† In the interest of standards development, A.T.U.S. offers full details on its test methods to other industry professionals on request.

Optional Microphones and Cables

AT831cT5 Miniature cardioid condenser microphone, terminated with a TA5F connector for use with the ATW-T101(x) transmitter. Includes clothing clip and windscreen.

MT830cT5 Subminiature omnidirectional condenser microphone, terminated with a TA5F connector for use with the ATW-T101(x) transmitter. Includes clothing clip and windscreens.

MT830cT5-TH "Theater" model, same as MT830cT5 except beige color mic and cable for concealment.

AT8340 Input cable connects mics with 3-pin XLRM-type output to ATW-T101(x) body-pack transmitter. 4.3' (1.3 m), XLRF to TA5F connectors.

AT8341 Output cable connects ATW-R100(x) receiver to camera or other device. 19' (0.5 m), XLRF to right-angle 3.5 mm stereo mini-plug.

For future reference, please record your system information here.

Receiver	ATW-R100	Serial Number	_____	_____	_____	_____	_____
	ATW-R100x	Serial Number	_____	_____	_____	_____	_____
Transmitter	ATW-T101	Serial Number	_____	_____	_____	_____	_____
	ATW-T101x	Serial Number	_____	_____	_____	_____	_____
	ATW-T102	Serial Number	_____	_____	_____	_____	_____
	ATW-T102x	Serial Number	_____	_____	_____	_____	_____

Audio-Technica U100 Series UHF Wireless Operating Frequencies

U100 Frequency and Channel Designator List

Designator	Frequency (MHz)	TV Channel	Designator	Frequency (MHz)	TV Channel
00	728.125	57	50	734.375	58
01	728.250	57	51	734.500	58
02	728.375	57	52	734.625	58
03	728.500	57	53	734.750	58
04	728.625	57	54	734.875	58
05	728.750	57	55	735.000	58
06	728.875	57	56	735.125	58
07	729.000	57	57	735.250	58
08	729.125	57	58	735.375	58
09	729.250	57	59	735.500	58
10	729.375	57	60	735.625	58
11	729.500	57	61	735.750	58
12	729.625	57	62	735.875	58
13	729.750	57	63	736.000	58
14	729.875	57	64	736.125	58
15	730.000	57	65	736.250	58
16	730.125	57	66	736.375	58
17	730.250	57	67	736.500	58
18	730.375	57	68	736.625	58
19	730.500	57	69	736.750	58
20	730.625	57	70	736.875	58
21	730.750	57	71	737.000	58
22	730.875	57	72	737.125	58
23	731.000	57	73	737.250	58
24	731.125	57	74	737.375	58
25	731.250	57	75	737.500	58
26	731.375	57	76	737.625	58
27	731.500	57	77	737.750	58
28	731.625	57	78	737.875	58
29	731.750	57	79	738.000	58
30	731.875	57	80	738.125	58
31	732.000	57	81	738.250	58
32	732.125	57	82	738.375	58
33	732.250	57	83	738.500	58
34	732.375	57	84	738.625	58
35	732.500	57	85	738.750	58
36	732.625	57	86	738.875	58
37	732.750	57	87	739.000	58
38	732.875	57	88	739.125	58
39	733.000	57	89	739.250	58
40	733.125	57	90	739.375	58
41	733.250	57	91	739.500	58
42	733.375	57	92	739.625	58
43	733.500	57	93	739.750	58
44	733.625	57	94	739.875	58
45	733.750	57	95	740.000	59
46	733.875	57	96	740.125	59
47	734.000	58	97	740.250	59
48	734.125	58	98	740.375	59
49	734.250	58	99	740.500	59

Multi-channel Systems

Following are groupings of frequencies suggested for multi-channel wireless systems.

Group A: Channels 00, 02, 08, 15, 46, 50, 60 (or 62), 71, 76, 80, 93, 99 -or-

Group B: Channels 01, 03, 07, 25, 30, 41, 44, 56, 69, 76 (or 77), 86

For use where TV Channel 57 is operating:

Channels 50, 60 (or 62), 71, 76, 80, 93, 99 (from Group A) -or-

Channels 56, 69, 76, 77, 86 (from Group B)

For use where TV Channel 58 is operating:

Channels 00, 02, 08, 15, 46, 99 (from Group A) -or-

Channels 01, 03, 07, 25, 30, 41, 44 (from Group B)

For use where TV Channel 59 is operating:

Channels 00, 02, 08, 15, 46, 50, 60 (or 62), 71, 76, 80, 93 (from Group A) -or-

Channels 01, 03, 07, 25, 30, 41, 44, 56, 69, 76 (or 77), 86 (All of Group B)

Audio-Technica U100x Series UHF Wireless Operating Frequencies

U100x Series Frequency and Channel Designator List

Designator	Frequency (MHz)	TV Channel	Designator	Frequency (MHz)	TV Channel
00	656.125	45	50	662.375	46
01	656.250	45	51	662.500	46
02	656.375	45	52	662.625	46
03	656.500	45	53	662.750	46
04	656.625	45	54	662.875	46
05	656.750	45	55	663.000	46
06	656.875	45	56	663.125	46
07	657.000	45	57	663.250	46
08	657.125	45	58	663.375	46
09	657.250	45	59	663.500	46
10	657.375	45	60	663.625	46
11	657.500	45	61	663.750	46
12	657.625	45	62	663.875	46
13	657.750	45	63	664.000	46
14	657.875	45	64	664.125	46
15	658.000	45	65	664.250	46
16	658.125	45	66	664.375	46
17	658.250	45	67	664.500	46
18	658.375	45	68	664.625	46
19	658.500	45	69	664.750	46
20	658.625	45	70	664.875	46
21	658.750	45	71	665.000	46
22	658.875	45	72	665.125	46
23	659.000	45	73	665.250	46
24	659.125	45	74	665.375	46
25	659.250	45	75	665.500	46
26	659.375	45	76	665.625	46
27	659.500	45	77	665.750	46
28	659.625	45	78	665.875	46
29	659.750	45	79	666.000	46
30	659.875	45	80	666.125	46
31	660.000	45	81	666.250	46
32	660.125	45	82	666.375	46
33	660.250	45	83	666.500	46
34	660.375	45	84	666.625	46
35	660.500	45	85	666.750	46
36	660.625	45	86	666.875	46
37	660.750	45	87	667.000	46
38	660.875	45	88	667.125	46
39	661.000	45	89	667.250	46
40	661.125	45	90	667.375	46
41	661.250	45	91	667.500	46
42	661.375	45	92	667.625	46
43	661.500	45	93	667.750	46
44	661.625	45	94	667.875	46
45	661.750	45	95	668.000	47
46	661.875	45	96	668.125	47
47	662.000	46	97	668.250	47
48	662.125	46	98	668.375	47
49	662.250	46	99	668.500	47

Multi-channel Systems

Following are groupings of frequencies suggested for multi-channel wireless systems.

Group A: Channels 00, 02, 08, 15, 46, 50, 60 (or 62), 71, 76, 80, 93, 99 -or-

Group B: Channels 01, 03, 07, 25, 30, 41, 44, 56, 69, 76 (or 77), 86

For use where TV Channel 45 is operating:

Channels 50, 60 (or 62), 71, 76, 80, 93, 99 (from Group A) -or-

Channels 56, 69, 76 (or 77), 86 (from Group B)

For use where TV Channel 46 is operating:

Channels 00, 02, 08, 15, 46, 99 (from Group A) -or-

Channels 01, 03, 07, 25, 30, 41, 44 (from Group B)

For use where TV Channel 47 is operating:

Channels 00, 02, 08, 15, 46, 50, 60 (or 62), 71, 76, 80, 93 (from Group A) -or-

Channels 01, 03, 07, 25, 30, 41, 44, 56, 69, 76 (or 77), 86 (All of Group B)

Ten Tips To Obtain The Best Results

1. Use only fresh alkaline batteries; replace the receiver batteries in pairs. Do not use "general purpose" (carbon-zinc) batteries.
2. Position the receiver so that it has the fewest possible obstructions between it and the normal location of the transmitter. Line-of-sight is best.
3. The transmitter and the receiver should be as close together as conveniently possible, but no closer together than three feet.
4. The receiver antennas should be in the open and away from any metal.
5. The transmitter and receiver must be set to the same channel number. (Use "x" units together and non-"x" units together.)
6. Only one transmitter on a given frequency should be "on" at a time.
7. The power switch on the transmitter has three positions: "Off," "Standby," and "On." In the middle "Standby" position, the transmitter sends only RF to the receiver; the audio source is turned off.
8. If the "Out Level" of the receiver is set too high, it may over-drive the input of the camera/mixer or clip the output of the receiver, causing distortion. Conversely, if the receiver output is set too low, the overall signal-to-noise ratio of the system may be reduced.
9. You need to change channels 1) when a strong interference signal is received, 2) when the channel breaks down, or 3) during multiple-system operation in order to select an interference-free channel. Always turn the units off before changing frequencies.
10. Turn the receiver and transmitter off when not in use. Remove the batteries during long-term storage.

One-Year Limited Warranty

Audio-Technica professional wireless systems purchased in the U.S.A. are warranted for one year from date of purchase by Audio-Technica U.S., Inc. (A.T.U.S.) to be free of defects in materials and workmanship. In event of such defect, product will be repaired promptly without charge or, at our option, replaced with a new product of equal or superior value if delivered to A.T.U.S. or an Authorized Service Center, prepaid, together with the sales slip or other proof of purchase date. **Prior approval from A.T.U.S. is required for return.** This warranty excludes defects due to normal wear, abuse, shipping damage, or failure to use product in accordance with the instructions. This warranty is void in the event of unauthorized repair or modification, or removal or defacing of the product labeling.

For return approval and shipping information, contact the Service Dept., Audio-Technica U.S., Inc., 1221 Commerce Drive, Stow, Ohio 44224.

Except to the extent precluded by applicable state law, **A.T.U.S. will have no liability for any consequential, incidental, or special damages; any warranty of merchantability or fitness for particular purpose expires when this warranty expires.**

This warranty gives you specific legal rights, and you may have other rights which vary from state to state.

Outside the U.S.A., please contact your local dealer for warranty details.



Audio-Technica U.S., Inc., 1221 Commerce Drive, Stow, Ohio 44224 330/686-2600 www.audio-technica.com

P#2323-02100 P51176-01-B/W ©2002 Audio-Technica U.S., Inc. Printed in Japan